

ES-650IV ES-650sIV

适用注塑机吨位：40~100ton
Injection Press Range: 40~100ton



STEC-NC2c

升级版多功能操作盒
Upgraded multifunctional pendant

功能更多样、操作更简单便捷
Variety function,
Operation more convenient and easily

综合参数 | GENERAL SPECIFICATIONS

电源 Power Source	常用气压 Air Pressure	驱动方式 Drive System	姿势(气缸) Posture (Air Cylinder)	气动姿势部推力 (气压:0.5Mpa时) Air Cylinder Driving Force (Air Pressure at 0.5Mpa)		控制箱 Control Box
				最大可搬重量 Max. Load	姿势力矩 Posture Torque	
AC200V ±10% 50/60Hz (单相) Single Phase	0.5Mpa	AC伺服马达 AC Servo Motor	90°固定 90° Fixed	标准姿势部:3kg (含夹具重量) Incl. Chuck Weight	5.0N·m	STEC-NC2c

机种 Model	行程(移动量)(mm) Stroke				电源设备容量 (KVA) Electric Consumpton	最大消费电力 (KW) Max Power Consumpton	机器重量(kg) Net Weight		空气消耗量 (Nℓ/周期) Air Consumption (Nℓ/Cycle)
	制品上下 Ⓟ Vertical	水口上下 Ⓡ Vertical	前后 Crosswise	走行 Traverse			本体 Main Body	操作盒 Pendant	
ES-650IV	650 [800]	—	75~555 [75~675]	1200 [1000]	1.4	1.1	173	1.1	1.63
ES-650sIV		700 [850]	Ⓟ 225~555 Ⓡ 104~434 [Ⓟ 225~675] [Ⓡ 104~554]	[1400] [1600]	2.6	1.7	191		

Ⓟ [] 尺寸表示选项行程。

Ⓞ 本体重量包括控制箱及电缆线的重量。

Ⓟ Ⓡ 表示制品侧手臂, Ⓡ 表示水口侧手臂。

Ⓞ 关于最大可搬重量, 详情请咨询敝司营业担当。

Ⓞ Figure in [] shows option stroke.

Ⓞ Net weight includes the weight of interlock box and driver box.

Ⓞ In the column of stroke, Ⓟ stands for product side arm and Ⓡ stands for runner side arm.

Ⓞ For details of the maximum allowable weight, please confirm with our sales man.

标准功能 | STANDARD FUNCTIONS

取出侧 Product Extract Side	<input checked="" type="checkbox"/> 取出下降待机 Delayed arm descent	<input checked="" type="checkbox"/> 前进取出侧姿势控制 Crosswise product extract side posture control	<input checked="" type="checkbox"/> 吸着确认单元 (1回路) Vacuum confirmation unit (1circuit)	<input checked="" type="checkbox"/> 自由滑移取出 Free extract for under-cut mold
	<input checked="" type="checkbox"/> 顶针联动 Ejector link	<input checked="" type="checkbox"/> 顶针后退联动 Ejector return link	<input checked="" type="checkbox"/> 水口模内开放 Runner release within mold	<input checked="" type="checkbox"/> 固定可动切换 Extraction from fixed mold
走行 Traverse	<input checked="" type="checkbox"/> 走行途中姿势 Posture control during traverse	<input checked="" type="checkbox"/> 浇口途中开放 (走行/复归) Midway sprue release (Traverse·Return)	<input checked="" type="checkbox"/> 不良品排出(可计数) Defective product reject (Countable)	
	<input checked="" type="checkbox"/> 横走行待机 Delayed traverse	<input checked="" type="checkbox"/> 水口途中开放(走行/复归) Midway runner release (Traverse·Return)	<input checked="" type="checkbox"/> 初期成型品排出 Initial products release	
落下侧 Product Release Side	<input checked="" type="checkbox"/> 落下侧下降途中姿势 Posture midway descent at release side	<input checked="" type="checkbox"/> 装箱点 Point packaging	<input checked="" type="checkbox"/> 自由装箱点 (2级, 共100点) Point free packaging (2 stage, 100 points)	<input checked="" type="checkbox"/> 输送带启动信号 Start signal of conveyer
其它 Other	<input checked="" type="checkbox"/> 3国语言切换 (简体中文、日文、英文) Three language exchange (Chinese(new), Japanese, English)	<input checked="" type="checkbox"/> 插入式用户编程 Easy NC steps (User program editing)	<input checked="" type="checkbox"/> 外部存储记忆 External storage memory	<input checked="" type="checkbox"/> 伺服休眠 Servo sleep feature
	<input checked="" type="checkbox"/> 设定值隐藏功能 Default blind feature	<input checked="" type="checkbox"/> 背景灯自动OFF Backlight Auto OFF	<input checked="" type="checkbox"/> USB通信端口 USB communication port	

选项功能 | OPTION FUNCTIONS

取出侧 Product Extract Side

- 吸着确认单元 (2回路)
Vacuum confirmation unit (2circuits)
- 吸着确认单元 (4回路)
Vacuum confirmation unit (4circuits)
- 夹具减压阀
Chuck pressure regulator
- 旋转功能
Rotation Unit
- 上升途中闭模
Mold close during arm ascent
- 制品确认 (LS-4)
Product confirmation LS-4

落下侧 Product Release Side

- 剪切回路(夹具内)
Air nipper in chuck circuit
- 制品2点开放
Release product at two different points
- 制品4点开放
Release product at four different points
- NT剪切·可动侧(有单元)
NT gate cutting on crossmember of moving mold side (w/unit)

其它 Other

- 警报灯 (红色·无蜂鸣器)
Alarm Lamp (Red color,w/o buzzer)
- 自动快速交换用夹具 (气压式)
Quick chuck change automatic (air sw)
- 操作盒支架
Pendant stand
- 欧规 12 (SPI)
EUROMAP 12 (SPI)
- 欧规 67
EUROMAP 67

外观尺寸 | OUTER DIMENSIONS

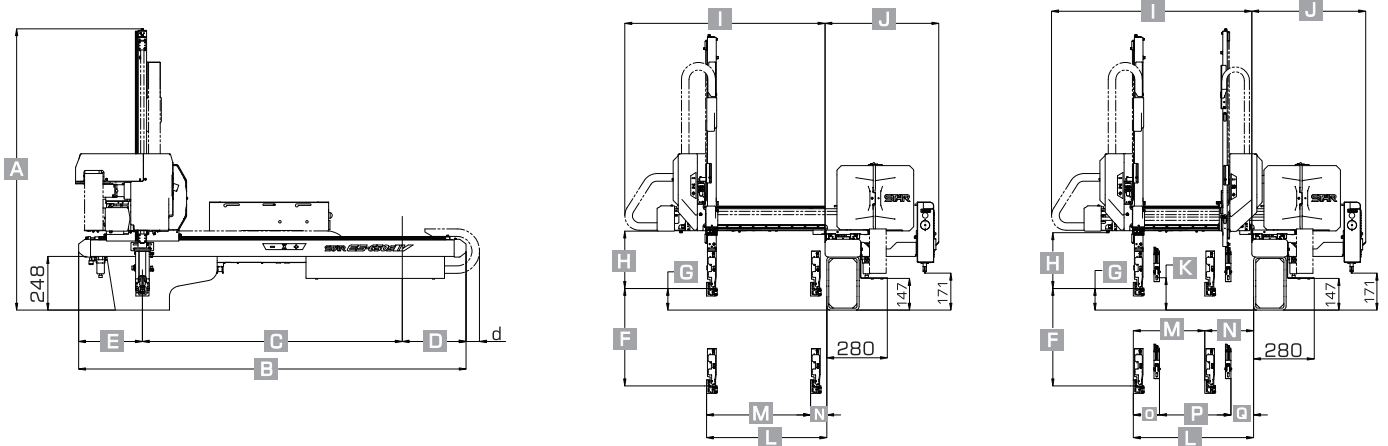

外形尺寸(mm) | OUTER DIMENSIONS

		ES-650IV	ES-650sIV	
A	全高 / Overall height	1272(1419 ¹)	1300(1436 ¹)	◎[]内的尺寸表示选项行程。 ◎水口夹的厚度为25mm。 ◎姿势部厚度为45mm,但根据配管方式不同,此尺寸多少会有些不同。 ◎水口侧上下行程比制品侧上下行程长50mm。 ◎*1表示F尺寸为800mm。 ◎*2表示C尺寸为1000mm。 ◎*3表示C尺寸为1400mm。 ◎*4表示C尺寸为1600mm。 ◎*5表示L尺寸为675mm。 ◎Figure in [] shows option stroke. ◎Thickness of runner chuck is basically about 25 mm. ◎Thickness of posture area is basically about 45 mm (depends on tubing) ◎Runner side vertical stroke is 50 mm longer than that of product side. ◎*1 When dimension F is 800 mm. ◎*2 When dimension C is 1000 mm. ◎*3 When dimension C is 1400 mm. ◎*4 When dimension C is 1600 mm. ◎*5 When dimension L is 675 mm. ※反操作时E值为309.[509] ² .[509] ³ .[309] ⁴ D值为281.[281] ² .[301] ³ .[301] ⁴ ※As anti-operator side E is 309.[509] ² .[509] ³ .[309] ⁴ D is 281.[281] ² .[301] ³ .[301] ⁴ ※d值正操作时为62.[62] ² .[0] ³ .[0] ⁴ 反操作时为77.[77] ² .[0] ³ .[0] ⁴ ※As operator side d is 62.[62] ² .[0] ³ .[0] ⁴ anti-operator side d is 77.[77] ² .[0] ³ .[0] ⁴
B	全幅 / Overall width	1790(1790 ²) (2210 ³ 2210 ⁴)		
C	走行行程 / Traverse stroke	1200(1000 ² 1400 ³ 1600 ⁴)		
D	落下侧突出位置 / Overhang,release side	295(295 ² 315 ³ 315 ⁴)		
E	取出侧突出位置 / Cable guide overhang	295(495 ² 495 ³ 295 ⁴)		
F	◎制品侧上下行程 / ◎Vertical stroke	650(800 ¹)		
G	◎制品侧上下待机位置 / ◎Vertical standby	100		
H	夹具安装位置上方有效尺寸 / Bottom of crosswise to chuck mount position	257		
I	前后单元 / Crosswise arm	925(1045 ⁵)		
J	本体厚度 / Thickness	525		
K	◎水口侧上下待机位置 ◎Vertical standby	—	150	
L	◎制品前进MAX ◎Crosswise reach max	555(675 ⁵)		
M	◎制品前进行程MAX ◎Crosswise stroke max	480(600 ⁵)	330(450 ⁵)	
N	◎制品前后待机MIN ◎Crosswise standby min	75	225	
O	◎◎接近MIN ◎◎Proximity min	—	121	
P	◎◎水口侧前后行程MAX ◎◎Crosswise stroke max	—	330(450 ⁵)	
Q	◎◎水口侧前后待机MIN ◎◎Crosswise standby min	—	104	

●因改良等原因,规格及外观有所变更时,不再另行通知,敬请包涵。All stated here is subject to change without advance notice.

星精机械(上海)有限公司
STAR SEIKI (SHANGHAI) CO., LTD.



STAR中国地区销售服务网络信息

<http://www.starseiki.cn>

华东地区

大陆地区总部:星精机械(上海)有限公司

地址:上海市徐汇区桂平路555号46栋208室

☎ +86-021-5423 4571

- 苏州事务所 ☎ +86-0512-6805 8385
- 厦门事务所 ☎ +86-0592-577 9994
- 余姚事务所 ☎ +86-0574-6253 2721
- 青岛分公司 ☎ +86-0532-5556 5517

华北/东北地区

- 天津分公司 ☎ +86-022-5838 7675
- 大连分公司 ☎ +86-0411-8756 2176

华南/西南/华中地区

- 深圳分公司 ☎ +86-0755-2962 2620
- 广州分公司 ☎ +86-020-3708 4205
- 武汉分公司 ☎ +86-027-8425 3500
- 重庆分公司 ☎ +86-023-6036 0877
- 成都分公司 ☎ +86-028-6549 5545
- 襄阳生产工厂 ☎ +86-0710- 3311 813

港澳台地区

- 香港公司 ☎ +852-2687 6745
- 中日龙股份有限公司(台北市)
☎ +886-2-2836 0039
- 台南营业所 ☎ +886-6-273 8985
- 台中营业所 ☎ +886-4-2463 1361